

ENGINE AND RELATED ITEMS:

- Air cleaner, double element, dry
- Variable speed cooling fan, with fan guard
- Engine, Komatsu SAA6D140E-5

ELECTRICAL SYSTEM:

- Alternator, 50 amp, 24 V
- Batteries, 170 Ah, 2 x 12 V
- Starting motors, 11kW
- Working lights-2 boom, 2 cab top front, 1 cab bottom
- Step light with timer
- Auto decelerator
- Electric priming pump

UNDERCARRIAGE:

- 610 mm 24" double grouser
- 8 track/3 carrier rollers (each side)
- Hydraulic track adjusters (each side)
- Variable track gauge
- Sealed track

GUARDS AND COVERS:

- Dust-proof net for radiator and oil cooler
- Pump/engine room partition cover
- Travel motor guards

OPERATOR ENVIRONMENT:

- Damper mount, all-weather, sound-suppressed cab with tinted safety glass windows, lockable door, intermittent window wiper and washer, floor mat, cigarette lighter and ashtray
- Multi-function color monitor, electronically-controlled throttle dials, electric service meter, gauges (coolant temperature, hydraulic oil temperature and fuel level), caution lights (electric charge, engine oil pressure, and air cleaner clogging), indicator lights (engine preheating and swing lock light) level check lights (coolant, engine oil, and hydraulic oil level), self-diagnostic system with trouble data memory
- Seat, fully adjustable with suspension
- Cab with pull-up type front window
- Rear view mirror (LH & RH)

*** OPTIONAL EQUIPMENT**

- Additional track guard
- Air suspension seat
- Alternator, 75 Amp, 24 V
- Arms (Backhoe):
PC800-8R:
—3600 mm 11'10" arm assembly
—4600 mm 15'1" arm assembly
—5600 mm 18'4" arm assembly
PC800SE-8R:
—2945 mm 9'8" SE arm assembly
- Auto air conditioner
- Booms (Backhoe):
PC800-8R:
—8200 mm 26'11" boom assembly
PC800SE-8R:
—7100 mm 23'4" boom assembly
- Cab front guard (ISO 10262 level 2)

- Cab with fixed front window
- Coolant heater
- Counterweight 11850 kg 26,120 lb
- Double flange track roller
- 12V electric supply
- Fire extinguisher
- Full length track guard
- General tool kit
- Grease gun, electric pump with indicator
- High cab mount
- Interconnected horn and warning light
- Large-capacity batteries
- Loading shovel attachments
- Lower wiper
- OPG top guard
- Provision for fast fuel fill
- Radio AM/FM

- Rain visor
- Seat belt 78 mm 3", 50 mm 2"
- Shoes:
—710 mm 28" double grouser
—810 mm 32" double grouser
—910 mm 36" double grouser
—1010 mm 40" double grouser
- Spare parts for first service
- Strengthened revolving frame underguard
- Sun visor
- Track frame undercover (center)
- Vandalism protection locks
- Working lights 2 (on cab)

HYDRAULIC CONTROLS:

- Fully hydraulic, with Electronic Open-Center Load-Sensing (EOLSS) and engine speed sensing (pump and engine mutual control system)
- Two axial piston motors for swing with single-stage relief valve
- One axial piston motor per track for travel with counter balance valve
- Two variable capacity piston pumps
- Two control valves, 5+4 spools (boom, arm, bucket, swing, and travel)
- Control levers, wrist control levers for arm, boom, bucket, and swing with PPC system
- Control levers and pedals for steering and travel with PPC system
- Oil cooler
- In-line filter
- Heavy lift mode system
- Shockless boom control
- Swing priority selection system
- Two-mode setting for boom

DRIVE AND BRAKE SYSTEM:

- Brakes, hydraulic lock travel brakes, oil disc parking
- Hydrostatic two travel speed system with planetary triple reduction final drive

OTHER STANDARD EQUIPMENT:

- Automatic swing holding brake
- Counterweight, 9800 kg 21,610 lb
- Horn, electric
- Marks and plates, English
- Paint, Komatsu standard
- Large handrails
- One-touch engine oil drainage
- PM tune-up service connector
- Remote greasing for radiator fan drive
- Travel alarm
- Rear reflector
- Anti-slip plates
- Corrosion resistor
- Water separator
- Catwalk

www.Komatsu.com

Printed in Japan 200804 IP.As(05)

KOMATSU[®]

KOMATSU[®]

PC800/800SE-8R BACKHOE
PC800-8R LOADING SHOVEL

PC
800



Photo may include optional equipment.

HYDRAULIC EXCAVATOR

WALK-AROUND

Productivity Features

- **High Work Equipment Speed**
Increased arm dumping and bucket dumping speed realize efficient loading operation.
- **Heavy Lift Mode**
The heavy lift mode increases lifting force by 10%.
- **Large Digging Force**
High operation efficiency with large digging force for severe applications.
- **Two-mode Setting for Boom**
Switch selection allows either powerful digging or smooth boom operation.
- **Twin Swing Motor System** provides excellent swing performance, even on slopes.
- **Large Drawbar Pull and Steering Force** provide excellent mobility.
- **Swing Priority Mode**
The swing priority mode improves efficiency for loading dump trucks at 90° or 180°.
- **Shockless Boom**
Switch selection reduces chassis vibration after sudden stops.

See page 5.

Excellent Reliability and Durability

- **KMAX Bucket Teeth** offer superior penetration and long-term sharpness.
- The fuel reliability is improved by adding **Fuel Main-filter and Water Separator** working against low grade fuel.
- **Fuel Pre-filter** with water separator equipped as standard.
- **O-ring Face Seals**, which have excellent sealing performance, are used for the hydraulic hoses.
- **High-pressure In-line Filtration**
The cool-running hydraulic system is protected with the most extensive filtration system available, including a high pressure in-line filter for each main pump.



Easy Maintenance

- **Easy Cleaning of Cooling Unit**
Fan reverse-rotation function facilitates clogged radiator cleaning.
- **Centralized Arrangement of Engine Checkpoints**
- **Anti-slip Plates** for improved foot traction
- **Large Handrail, Step and Catwalk** provide easy access to the engine and hydraulic equipment.
- **Increased Fuel Tank Capacity**
- **Electric Priming Pump** installed.

See page 10.

- **Highly Reliable Electronic Devices**
Exclusively designed electronic devices have passed severe testing.
 - Controllers • Sensors • Connectors
 - Heat resistant wiring • Circuit breaker
- **Boom Foot Hoses** are arranged under the boom foot, improving hose life and safety.

See page 6.

Ecology and Economy Features

- **High Power Komatsu SAA6D140E-5 Engine**
 - Powerful turbocharged and air-to-air aftercooled Komatsu SAA6D140E-5 engine provides **363 kW** 487 HP.
 - Offers high power and low fuel consumption.
 - Equipped with an electronically controlled variable speed fan.

- **Economy Mode Four-level Setting**
Enables operator to select the appropriate Economy mode level to match production requirement with lowest fuel consumption.
- **Reduction of Ambient Noise**
Meets the EU Stage 2 noise regulations.
 - Electronically controlled variable speed fan drive
 - Large hybrid fan
 - Glasswool-furnished low-noise muffler and noise reducing cover around the muffler

See page 4.



Photo may include optional equipment.

Working Environment

- **Large Comfortable Cab**
 - Low noise and vibration with cab damper mounting
 - Large-capacity air conditioner (optional)
 - Pressurized cab prevents external dust from entering
 - OPG top guard level 2 (by ISO 10262 standard) capable with optional bolt-on top guard.

See pages 8, 9.



Advanced Monitor Features

- Machine condition can be checked with Equipment Management Monitoring System (EMMS). See page 11.
- Two working modes combine with heavy lift mode for maximum productivity. See page 5.

HORSEPOWER
Gross:370 kW 496 HP @ 1800 rpm
Net:363 kW 487 HP @ 1800 rpm

OPERATING WEIGHT
Backhoe
74200 – 77810 kg
163,580 – 171,540 lb
Loading shovel
77000 kg
169,750 lb

PRODUCTIVITY & ECOLOGY FEATURES

Komatsu Technology

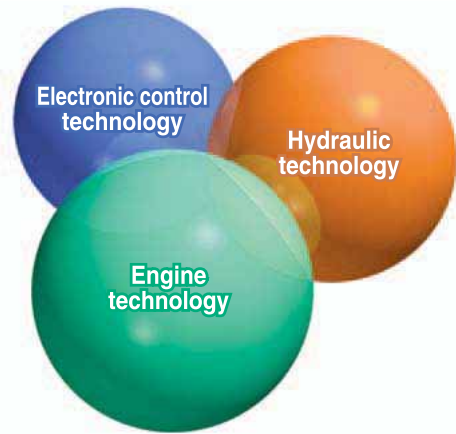

Komatsu develops and produces all major components, such as engines, electronics and hydraulic components, in house. With this "Komatsu Technology," and adding customer feedback, Komatsu is achieving great advancements in technology. To achieve both high levels of productivity and economical performance, Komatsu has developed the main components with a total control system. The result is a new generation of high performance and environment friendly excavators.

High Power Komatsu SAA6D140E Engine

Powerful turbocharged and air-to-air aftercooled Komatsu SAA6D140E-5 engine provides **363 kW** 487 HP. This Komatsu SAA6D140E engine actualizes high-power to low fuel consumption with the optimum fuel injection by electronic heavy duty HPCR (High Pressure Common Rail) fuel injection system.

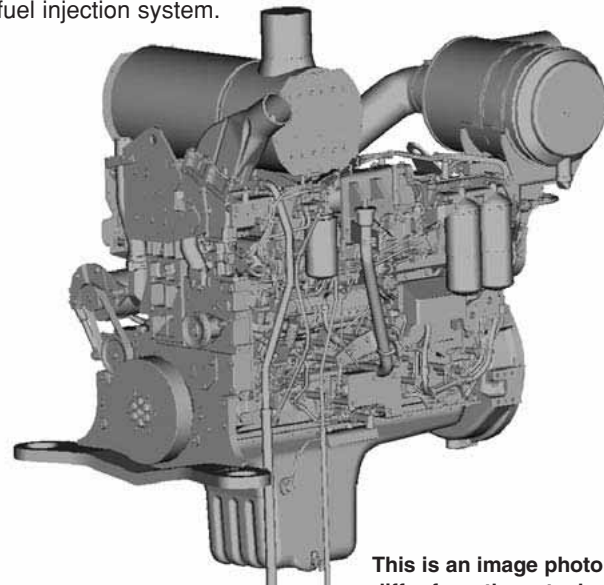

This is an image photo: may differ from the actual engine.

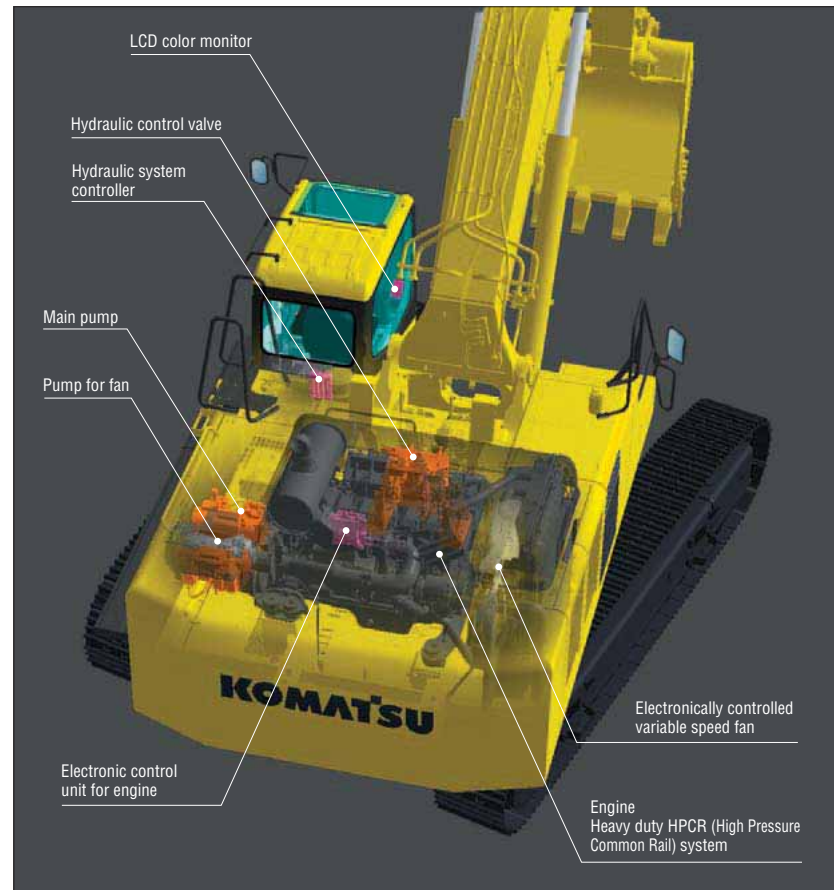

Electronically Controlled Variable Speed Fan Contributes to Low Fuel Consumption and Low Noise

The electronic control system sets the rotational speed of the cooling fan according to the coolant, hydraulic oil, and ambient temperature; effectively uses the engine output to prevent wasteful fuel consumption; and reduces noise during low-speed fan rotation.



Lower and Economical Fuel Consumption Using Economy Mode

Enables operator to set the Eco mode to up to four levels according to working conditions so that production requirement is achieved at lowest possible fuel consumption.

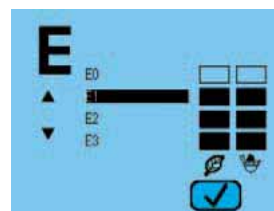

Reduction of Ambient Noise (optional)

Reduced noise by adoption of an electronically controlled variable speed fan drive, large hybrid fan, low-noise muffler and cover with glasswool, to meet EU Stage 2 noise regulations.

Large Digging Force

Thanks to the high engine output and an excellent hydraulic system, this machine demonstrates powerful digging force.

Maximum arm crowd force (ISO):
250 kN 25.5 ton
Maximum bucket digging force (ISO):
333 kN 34.0 ton

Work Equipment Speed Increased

An arm quick return circuit is provided for arm dumping. This returns a portion of oil flow directly to the hydraulic tank at arm dumping to reduce the hydraulic pressure loss. Combined with increased bucket dumping speed, faster loading work is realized.

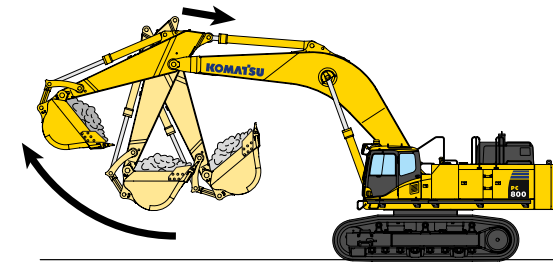

Large Drawbar Pull and Steering Force

Since the machine has a large drawbar pull and a high steering force, it demonstrates excellent mobility even when it is being used on inclined sites.

Two-mode Setting for Boom

Smooth mode provides easy operation for gathering blasted rock and scraping operations. When maximum digging force is needed, switch to **power mode** for more effective excavating.

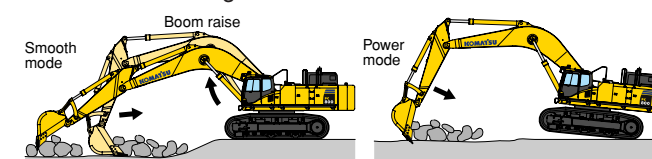

Shockless Boom Control

The PC800-8R boom circuit features a shockless valve (double-check slow return valve) to automatically reduces the amount of vibration present when operating the boom. Operator fatigue is reduced (which can improve safety and productivity), and spillage caused by vibration is minimized.

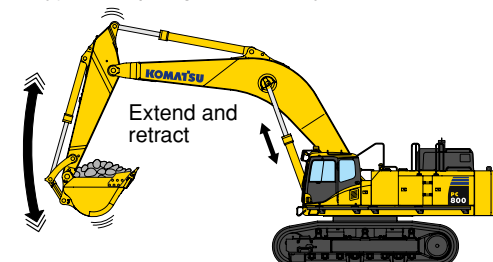

Working Mode Selection

Power and Economy Mode

The PC800-8R excavator is equipped with two working modes. Each mode is designed to match engine speed, pump flow, and system pressure to the current application, giving the operator flexibility to match equipment performance to the job at hand.

Working Mode	Application	Advantage
P	Power Mode	<ul style="list-style-type: none"> • Maximum production/power • Fast cycle time
E (E0,E1,E2,E3)	Economy Mode	<ul style="list-style-type: none"> • Good cycle time • Good fuel economy

Heavy Lift Mode

Gives the operator 10% more lifting force on the boom when needed for handling rock or heavy lifting applications.

Swing Priority Setting

The swing priority setting allows the operator to use the same easy motion for 180° loading as 90° loading operations. By altering the oil flow, this setting allows you to select either boom or swing as the priority for increased production.

Selection	Result
ON	Oil flow to the swing motor is increased. 180° loading operations are most efficient.
OFF	Oil flow to the boom is increased. 90° loading operations are most efficient.



RELIABILITY FEATURES

Excellent Reliability and Durability

Boom Foot Hoses

The boom foot hoses are arranged under the boom foot to reduce hose bend during operation, extending hose life and improving operator safety.



O-ring Face Seal

The hydraulic hose seal method has been changed from a conventional taper seal to an O-ring seal. This provides improved sealing performance during operation.

Fuel Pre-filter (with Water Separator)

Removes water and contaminants from fuel to enhance the fuel system reliability.



Fuel Main-filter

The reliability of fuel systems is improved, because fuel main-filter additionally installed removes contamination and sludge contained in fuel.



High-pressure In-line Filtration

The PC800-8R has the most extensive filtration system available, providing in-line filters as standard equipment. An in-line filter in the outlet port of each main hydraulic pump reduces failures caused by contamination.

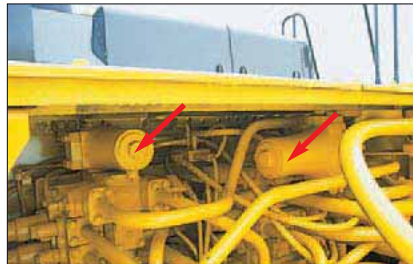

Metal Guard Rings

Metal guard rings protect all the hydraulic cylinders and improve reliability.

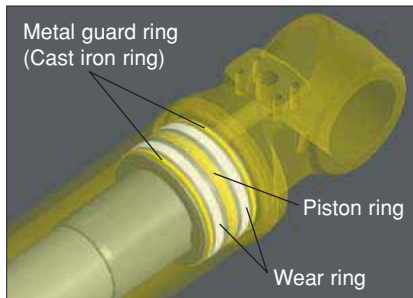

Heat-resistant Wiring

Heat-resistant wiring is utilized for the engine electric circuit and other major component circuit.

Water Separator

Removes water from the fuel and improves the reliability of fuel systems.



Sturdy Undercarriage

The undercarriage is strengthened to provide excellent reliability and durability when working on rocky ground or blasted rock.

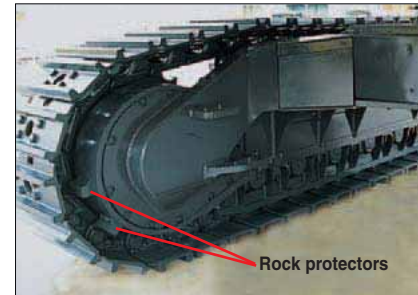

Sturdy guards shield the travel motors and piping against damage from rocks.



Track roller guard (full length) (optional)

DT-type Connectors

DT-type connectors seal tight and have higher reliability.

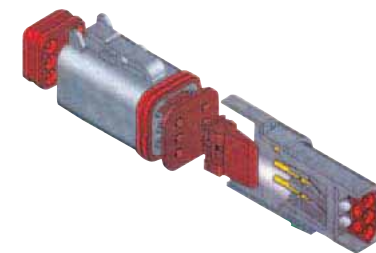

Circuit Breaker

With circuit breaker, the machine can be easily restarted after repair.



Strengthened Quarry Bucket Provides Outstanding Wear-resistance (optional for PC800SE-8R)

The bucket for specific use in quarry is impact and wear resistant, providing high performance and long life. Koma-hard materials* provide excellent wear resistance. Combined with adoption of long-life KMAX teeth, durability of bucket is drastically enhanced.

* Koma-hard materials (KVX materials):
Komatsu developed, wear-resistant, reinforced materials.
Brinell hardness: 500 or more (180kgf/mm² class).
Features high wear-resistance and little quality change from the heat generated during rock loading, maintaining long term hardness.

KMAX Tooth

- Unique bucket tooth shape, superior digging performance
- Long-term high sharpness
- Great penetration performance
- Hammerless, safe, and easy tooth replacement
(Tooth replacement time: Halves the conventional machine.)

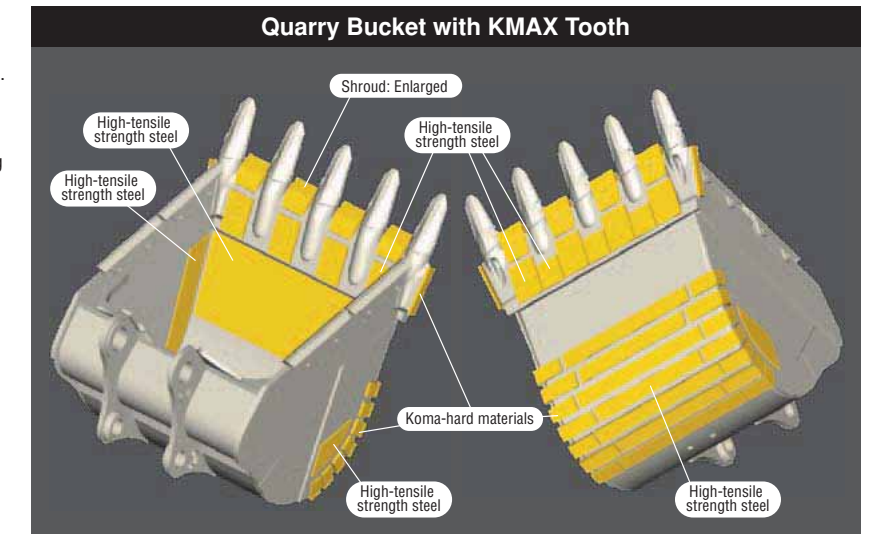

STEP 1



STEP 2

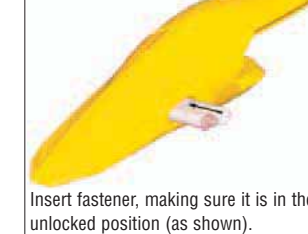

STEP 3

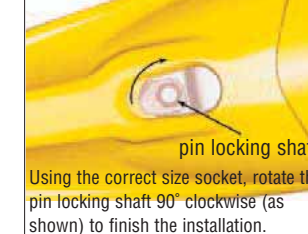

STEP 4



Photo is PC850-8R.
Photo may include optional equipment.

WORKING ENVIRONMENT

The cab interior is spacious and provides a comfortable working environment...

Large Comfortable Cab

Comfortable Cab

New PC800-8R's cab offers an exceptionally comfortable operating environment. The large cab enables full flat reclining of the seat back with headrest.

Pressurized Cab

The optional air conditioner, air filter and a higher internal air pressure (6.0 mm Aq 0.2" in Aq) prevent external dust from entering the cab.

Low Noise Design

Noise level is remarkably reduced, not only engine noise but also swing and hydraulic relief noise.

Low Vibration with Cab Damper Mounting

PC800-8R uses a new, improved cab damper mount system that incorporates longer stroke and the addition of a spring. The new cab damper mounting combined with a strengthened left and right side deck, aids vibration reduction at the operator's seat.

Vibration at floor is reduced from 120 dB (VL) to 115 dB (VL).

dB (VL) is index for expressing size of vibration.

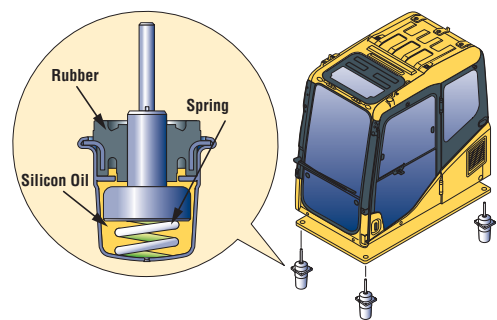

Comparison of Riding Comfort

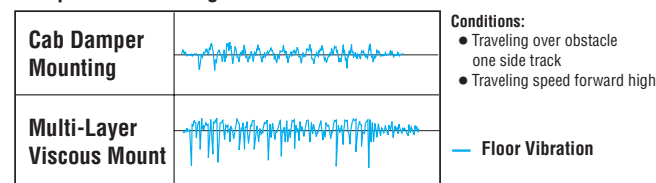

Vertical direction on graph shows size of vibration.



Photo may include optional equipment.

Automatic Air Conditioner (optional)

A 6,900 kcal air conditioner is utilized. The bi-level control function keeps the operator's head and feet cool and warm respectively. This improved air flow function keeps the inside of the cab comfortable throughout the year.

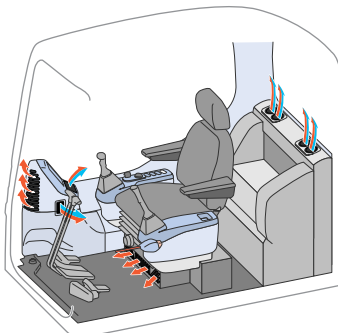

Skylight



Sliding Window

Washable Cab Floormat

The PC800-8R's cab floormat is easy to keep clean. The gently inclined surface has a flanged floormat and drainage holes to facilitate runoff.



Seat with headrest reclined full flat

Photo may include optional equipment.

Multi-position Controls

The multi-position, PPC (proportional pressure control) levers allow the operator to work in comfort while maintaining precise control. A double-slide mechanism allows the seat and control levers to move together or independently, allowing the operator to position the controls for maximum productivity and comfort.



Seat Sliding Amount: 340 mm 13.4", increased 120 mm 4.7"



Defroster (optional)



Cab Frame Mounted Wiper



Bottle Holder and Magazine Rack

Safety Features

Step Light with Timer provides light for about one minute to allow the operator to get off the machine safely.



Pump/engine Room Partition prevents oil from spraying on the engine if a hydraulic hose should burst.



Thermal and Fan Guards are placed around high-temperature parts of the engine and fan drive.

Anti-slip Plates

Spiked plates on working surfaces provide anti-slip performance.

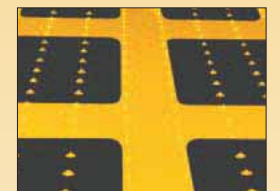

Anti-slip Plates

Horn Interconnected with Warning Light (optional) gives visual and audible notice of the excavator's operation when activated.

EASY MAINTENANCE FEATURES

Komatsu Designed the PC800-8R for Easy Service Access.

Easy Checking and Maintenance of Engine

Engine check points are concentrated on one side of the engine to facilitate daily checks. Thermal guards are placed around high-temperature parts such as turbocharger.



One-touch Drain Cock

Easier, cleaner engine oil changes.

Reduced Maintenance Costs

High performance filters are used in the hydraulic circuit and engine. Longer hydraulic oil, hydraulic oil filter, engine oil and engine oil filter element replacement intervals significantly reduce maintenance costs.



Easy Cleaning of Radiator

Reverse-rotation function of the hydraulic driven fan facilitates cleaning of the cooling unit.



Electric Operated Grease Gun Equipped with Hose Reel (optional)

Greasing is made easy with the electric operated grease gun and indicator.

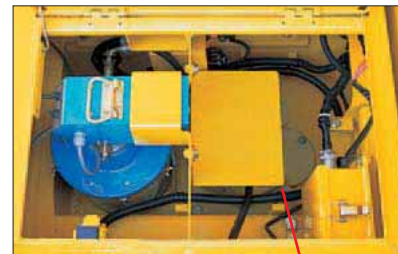

Grease can drum storage location

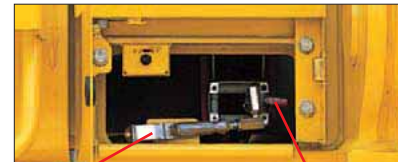

Grease gun
The grease gun can be reached from ground level.

Indicator

Convenient Utility Space

Utility space provides great convenience to store tools, spare parts, etc.



Increased Fuel Tank Capacity

Fuel tank capacity is increased from 880 ltr 232 U.S. gal to 980 ltr 259 U.S. gal to extend operating hours before refueling.

Dust Indicator with 5-step Indication

Informs of air cleaner clogging in 5 steps to warn of filter condition.



Wide Catwalk and Large Handrails

Easier, safer operator cab access and maintenance checks.



Steps Connected to the Machine Cab

Steps allows access from left hand catwalk to top of machine for engine check and maintenance.



Divided Type Engine Cover

The divided engine cover allows inspection points around the engine to be easily accessed.

Electric Priming Pump

Bleeding air from fuel system is easily accomplished with the electric priming pump.



Electric priming pump switch

High-Quality EMMS Self-diagnostic System

• Abnormality checking function

In case any abnormality should occur, the monitoring system checks whether hydraulic pressure, solenoid ON/OFF status, engine speed, electrical connections, etc. are in the normal conditions to keep the machine downtime to a minimum.

• Maintenance history memory function

Maintenance records such as replacement of engine oil, hydraulic oil, filters, etc. can be stored.

• Trouble data memory function

All the trouble data are stored to serve as references for future trouble-shooting.

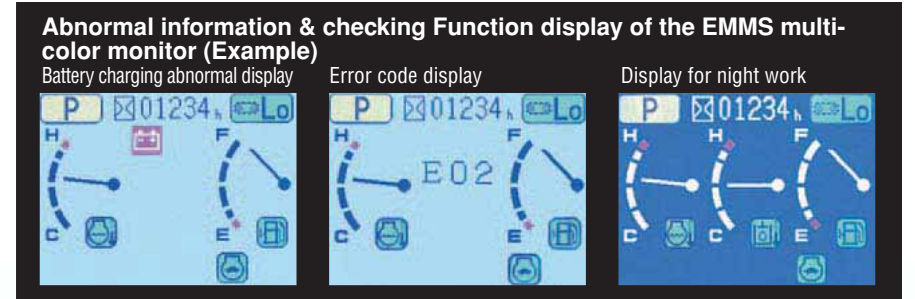
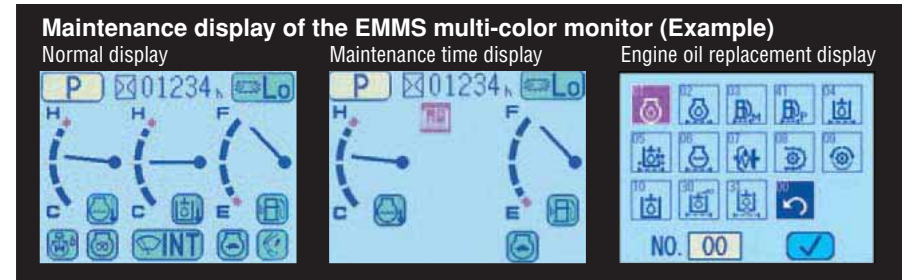

Photo may include optional equipment.

SPECIFICATIONS



ENGINE

Model Komatsu SAA6D140E-5
 Type 4-cycle, water-cooled, direct injection
 Aspiration Turbocharged, aftercooled
 Number of cylinders 6
 Bore **140 mm 5.51"**
 Stroke **165 mm 6.50"**
 Piston displacement **15.24 ltr 930 in³**
 Governor All-speed, electronic
 Horsepower:
 SAE J1995 Gross **370 kW 496 HP**
 ISO 9249 / SAE J1349* Net **363 kW 487 HP**
 Rated rpm 1800 rpm
 Fan drive type Hydraulic

*Net horsepower at the maximum speed of radiator cooling fan is 338 kW 454HP.



HYDRAULIC SYSTEM

Type Open-center load-sensing system
 Number of selectable working modes 2

Main pump:
 Type Variable-capacity piston pumps
 Pumps for Boom, arm, bucket, swing, and travel circuits
 Maximum flow **2 x 494 ltr/min** 2 x 130.5 U.S. gpm

Fan drive pump Variable capacity piston type
 Hydraulic motors:
 Travel 2 x axial piston motor with parking brake
 Swing 2 x axial piston motor with swing holding brake

Relief valve setting:
 Implement circuits **31.4 MPa** 320 kg/cm² 4,550 psi
 Travel circuit **34.3 MPa** 350 kg/cm² 4,980 psi
 Swing circuit **28.4 MPa** 290 kg/cm² 4,120 psi
 Heavy lift circuit **34.3 MPa** 350 kg/cm² 4,980 psi
 Pilot circuit **2.9 MPa** 30 kg/cm² 430 psi

Hydraulic cylinders:
 Number of cylinders—bore x stroke
 Boom **2 – 200 mm x 1950 mm** 7.9" x 76.8"
 Arm
 Std **1 – 200 mm x 2250 mm** 7.9" x 88.6"
 SE **2 – 185 mm x 1610 mm** 7.3" x 63.4"
 Bucket
 Std **1 – 185 mm x 1610 mm** 7.3" x 63.4"
 SE **1 – 225 mm x 1420 mm** 8.9" x 55.9"



SWING SYSTEM

Driven method Hydraulic motors
 Swing reduction Planetary gear
 Swing circle lubrication Grease-bathed
 Swing lock Oil disc brake
 Swing speed 6.8 rpm



DRIVES AND BRAKES

Steering control Two levers with pedals
 Drive method Fully hydrostatic
 Travel motor Axial piston motor, in-shoe design
 Reduction system Planetary triple reduction
 Maximum drawbar pull **559 kN 57000 kg 125,660 lb**
 Gradeability 70%
 Maximum travel speed
 Low **2.8 km/h 1.7 mph**
 High **4.2 km/h 2.6 mph**
 Service brake Hydraulic lock
 Parking brake Oil disc brake



UNDERCARRIAGE

Center frame H-leg frame
 Track frame Box-section
 Seal of track Sealed
 Track adjuster Hydraulic
 No. of shoes 47 each side
 No. of carrier rollers 3 each side
 No. of track rollers 8 each side



COOLANT AND LUBRICANT CAPACITY (REFILLING)

Fuel tank **980 ltr** 258.9 U.S. gal
 Radiator **100 ltr** 26.4 U.S. gal
 Engine **55 ltr** 14.5 U.S. gal
 Final drive, each side **20 ltr** 5.3 U.S. gal
 Swing drive **24.5 x 2 ltr** 6.5 x 2 U.S. gal
 Hydraulic tank **440 ltr** 116.2 U.S. gal



OPERATING WEIGHT (APPROXIMATE)

PC800-8R: Operating weight, including **8200 mm 26'11"** boom, **3600 mm 11'10"** arm, SAE heaped **3.1 m³ 4.05 yd³** backhoe bucket, operator, lubricant, coolant, full fuel tank, and the standard equipment.

PC800SE-8R: Operating weight, including **7100 mm 23'4"** boom, **2945 mm 9'8"** arm, SAE heaped **4.0 m³ 5.23 yd³** backhoe bucket, operator, lubricant, coolant, full fuel tank, and the standard equipment.

Shoes	PC800-8R		PC800SE-8R	
	Operating Weight	Ground Pressure	Operating Weight	Ground Pressure
610 mm 24"	74200 kg 163,580 lb	121 kPa 1.23 kgf/cm ² 17.5 psi	75200 kg 165,790 lb	122 kPa 1.24 kgf/cm ² 17.6 psi
710 mm 28"	75000 kg 165,350 lb	105 kPa 1.07 kgf/cm ² 15.2 psi	76000 kg 165,550 lb	106 kPa 1.08 kgf/cm ² 15.4 psi
810 mm 32"	75530 kg 166,510 lb	92.2 kPa 0.94 kgf/cm ² 13.4 psi	76530 kg 168,720 lb	93.2 kPa 0.95 kgf/cm ² 13.5 psi
910 mm 36"	76170 kg 167,920 lb	83.3 kPa 0.85 kgf/cm ² 12.1 psi	77170 kg 170,130 lb	84.3 kPa 0.86 kgf/cm ² 12.2 psi
1010 mm 40"	76810 kg 169,340 lb	75.5 kPa 0.77 kgf/cm ² 10.9 psi	77810 kg 171,540 lb	76.5 kPa 0.78 kgf/cm ² 11.1 psi



BACKHOE DIMENSIONS

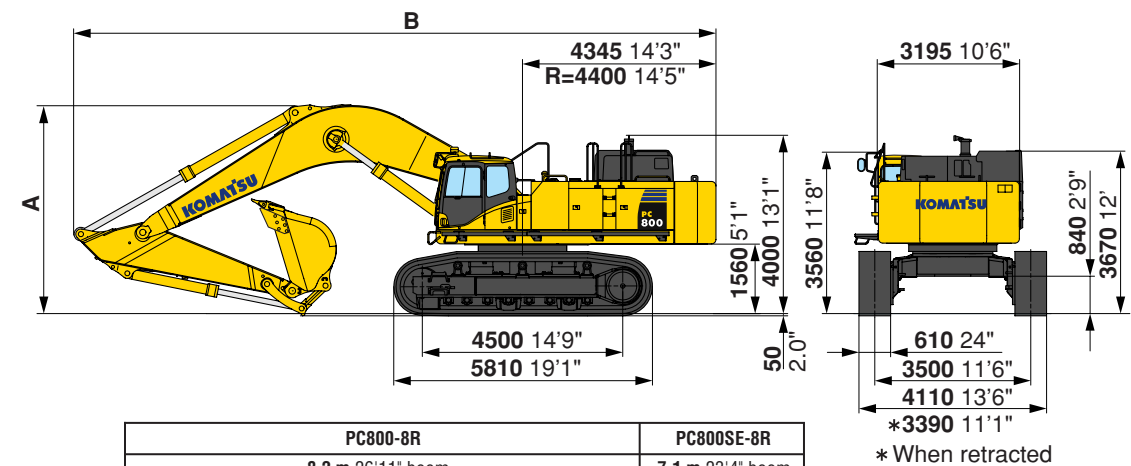

WORKING RANGE

Unit: mm ft in

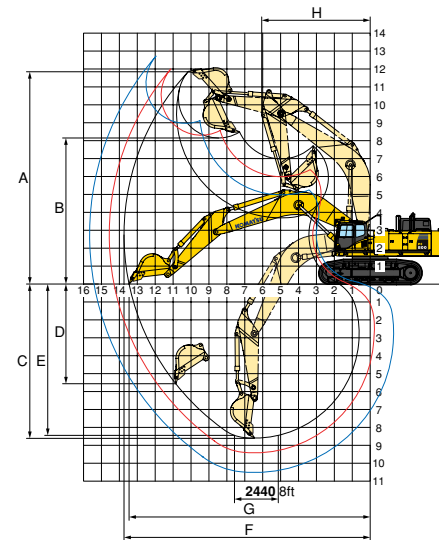

	PC800-8R			PC800SE-8R
	8200 mm 26'11"			
	3600 mm 11'10"	4600 mm 15'1"	5600 mm 18'4"	2945 mm 9'8"
A Max. digging height	11840 mm 38'10"	12000 mm 39'4"	12690 mm 41'8"	11330 mm 37'2"
B Max. dumping height	8145 mm 26'7"	8295 mm 27'3"	8890 mm 29'2"	7525 mm 24'8"
C Max. digging depth	8600 mm 28'3"	9590 mm 31'6"	10595 mm 34'9"	7130 mm 23'5"
D Max. vertical wall digging depth	5575 mm 18'3"	6575 mm 21'7"	7920 mm 26'0"	4080 mm 13'5"
E Max. digging depth of cut for 8' level	8445 mm 27'8"	9455 mm 31'0"	10500 mm 34'5"	6980 mm 22'11"
F Max. digging reach	13740 mm 45'1"	14575 mm 47'1"	15635 mm 51'4"	12265 mm 40'3"
G Max. digging reach at ground level	13460 mm 44'2"	14310 mm 46'1"	15385 mm 50'6"	11945 mm 39'2"
H Min. swing radius	6060 mm 19'11"	6085 mm 20'0"	6145 mm 20'2"	5645 mm 18'6"
Bucket digging force (SAE)	296 kN 30200 kgf / 66,580 lb	296 kN 30200 kgf / 66,580 lb	296 kN 30200 kgf / 66,580 lb	391 kN 39900 kgf / 87,960 lb
Arm crowd force (SAE)	237 kN 24200 kgf / 53,350 lb	214 kN 21800 kgf / 48,060 lb	181 kN 18500 kgf / 40,790 lb	331 kN 33800 kgf / 74,520 lb
Bucket digging force (ISO)	333 kN 34000 kgf / 74,960 lb	333 kN 34000 kgf / 74,960 lb	333 kN 34000 kgf / 74,960 lb	431 kN 43900 kgf / 96,780 lb
Arm crowd force (ISO)	250 kN 25500 kgf / 56,220 lb	222 kN 22600 kgf / 49,820 lb	183 kN 19100 kgf / 42,110 lb	341 kN 34800 kgf / 76,720 lb



BACKHOE BUCKET, ARM, AND BOOM COMBINATION

BUCKET CAPACITY (HEAPED)				WIDTH		WEIGHT (with side cutters)		ARM LENGTH			
SAE, PCSA m ³ yd ³	CECE m ³ yd ³	Without side shrouds, side cutters	With side shrouds, side cutters	mm	in						kg
PC800-8 (use with 8.2 m boom)						3.6	11'10"	4.6	15'1"	5.6	18'4"
2.8	3.66	2.5	3.27	1550	51.0"	1695	66.7"	2740	6,040	○	○
3.1	4.05	2.8	3.66	1700	66.9"	1880	74.0"	2960	6,530	○	□
3.4	4.45	3.0	3.92	1820	71.7"	1920	75.6"	3500	7,720	□	—
PC800SE-8 (use with 7.1 m boom)						2.9			9'8"	○	□
4.0	5.23	3.5	4.58	2000	78.7"	2100	82.8"	3435	7,570	○	□
4.3	5.62	3.8	4.97	2150	84.6"	2250	88.7"	3870	8,530	□	□
4.5	5.89	4.0	5.23	2230	91.9"	2330	91.7"	4050	8,930	□	□

These charts are based on over-side stability with fully loaded bucket at maximum reach.
 ○ : General purpose use, density up to 1.8 t/m³ 3,000 lb/yd³ □ : General purpose use, density up to 1.5 t/m³ 2,500 lb/yd³
 — : Not useable

LOADING SHOVEL DIMENSIONS

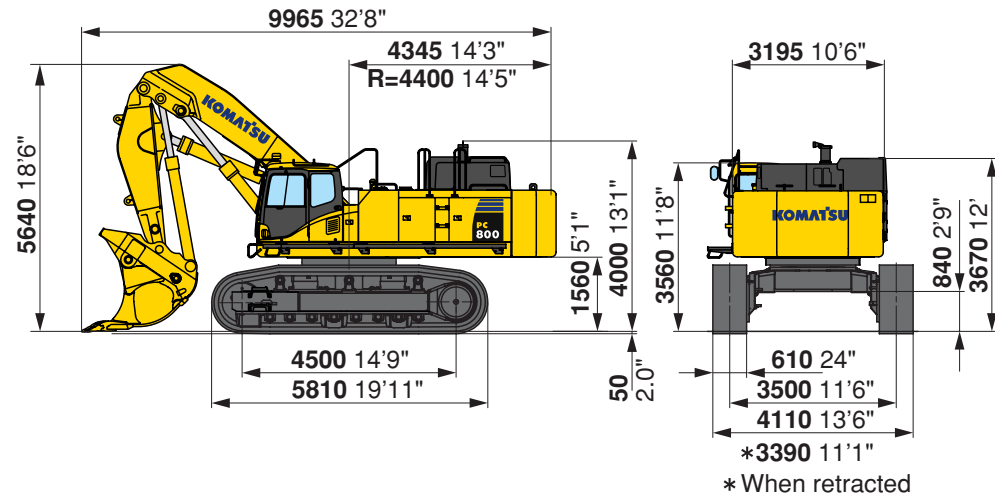

LOADING SHOVEL WORKING RANGE AND BUCKET SELECTION

Working Range

Type of bucket	Bottom dump			
	4.5 m ³ 5.9 yd ³		5.1 m ³ 6.7 yd ³	
A Max. cutting height	10635 mm 34'11"			
B Max. dumping height	7180 mm 23'7"			
C Max. digging depth	3535 mm 11'7"			
D Max. digging reach	10305 mm 33'10"			
E Max. digging reach at ground level	9920 mm 32'7"			
F Level crowding distance	3875 mm 12'9"			
G Min. crowd distance	5620 mm 18'5"			
Bucket digging force	477 kN 48600 kg 107,140 lb			
Arm crowd force	404 kN 41200 kg 90,830 lb			

Bucket Selection

Type of bucket	Bottom dump			
	4.5 m ³ 5.9 yd ³		5.1 m ³ 6.7 yd ³	
Capacity—heaped	4.5 m ³ 5.9 yd ³		5.1 m ³ 6.7 yd ³	
Width	2320 mm 91.3"		2670 mm 105.1"	
Weight	5700 kg 12,570 lb		7360 kg 16,230 lb	
No. of bucket teeth	6			
Recommended uses	General-purpose digging and loading		Light-duty excavation and loading	

LOADING SHOVEL OPERATING WEIGHT

Operating weight, including 4600 mm 15'1" boom, 3400 mm 11'2" arm, 4.5 m³ 5.9 yd³ heaped bucket, operator, lubricants, coolant, full fuel tank and standard equipment.

Shoes	Operating Weight	Ground Pressure
610 mm 24"	77000 kg 169,750 lb	125 kPa/1.27 kg/cm ² 18.1 PSI

LIFTING CAPACITY

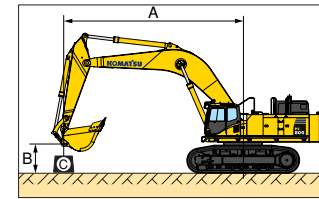

PC800-8R

- Equipment:
- Boom: 8.2 m 26'11"
 - Arm: 3.6 m 11'10"
 - Bucket: 3.1 m³ 4.05 yd³
 - Shoe: 610 mm 24"
 - Counterweight: 9.8 ton 21,610 lb

- A: Reach from swing center
B: Bucket hook height
C: Lifting capacity
Cf: Rating over front
Cs: Rating over side
⊗: Rating at maximum reach

HEAVY LIFTING "OFF"

B \ A	⊗ Maximum		9.0 m 29'		7.5 m 24'		6.0 m 19'		4.5 m 14'		3.0 m 9'	
	Cf	Cs	Cf	Cs	Cf	Cs	Cf	Cs	Cf	Cs	Cf	Cs
6.0 m 19'	*7700 *17,000	*7700 *17,000	*12150 *26,700	*12150 *26,700	*13950 *30,800	*13950 *30,800						
3.0 m 9'	*9000 *19,800	7050 15,500	*14500 *32,000	12000 26,400	*17850 *39,400	16200 35,700	*23750 *52,400	22900 50,500				
0 m 0'	9250 20,400	6950 15,300	14100 31,100	10750 23,700	18900 41,600	14300 31,600	*26650 *58,700	20250 44,700	*13450 *29,700	*13450 *29,700		
-3.0 m -9'	10900 24,100	8250 18,100	13700 30,200	10350 22,800	18400 40,500	13850 30,500	*25150 *55,400	20000 44,000	*26650 *58,800	*26650 *58,800	*19000 *41,900	*19000 *41,900
-6.0 m -19'	*13700 *30,200	13500 29,800			*14800 *32,600	14650 32,300	*19000 *41,900	*19000 *41,900	*24050 *53,100	*24050 *53,100		

Unit: kg lb

HEAVY LIFTING "ON"

B \ A	⊗ Maximum		9.0 m 29'		7.5 m 24'		6.0 m 19'		4.5 m 14'		3.0 m 9'	
	Cf	Cs	Cf	Cs	Cf	Cs	Cf	Cs	Cf	Cs	Cf	Cs
6.0 m 19'	*8700 *19,200	8300 18,300	*13900 *30,700	13600 30,000	*15900 *35,100	*15900 *35,100						
3.0 m 9'	9250 20,400	7050 15,500	15400 34,000	12000 26,400	*20400 *45,000	16200 35,700	*27050 *59,600	22900 50,500				
0 m 0'	9250 20,400	6950 15,300	14100 31,100	10750 23,700	18900 41,600	14300 31,600	27200 59,900	20250 44,700	*15050 *33,100	*15050 *33,100		
-3.0 m -9'	10900 24,100	8250 18,100	13700 30,200	10350 22,800	18400 40,500	13850 30,500	26900 59,300	20000 44,000	*29500 *65,000	*29500 *65,000	*21100 *46,500	*21100 *46,500
-6.0 m -19'	*15950 *35,100	*13500 *29,800			*17150 *37,800	14650 32,300	*21950 *48,400	21100 46,500	*27800 *61,200	*27800 *61,200		

Unit: kg lb

* Load is limited by hydraulic capacity rather than tipping. Ratings are based on SAE standard No. J1097. Rated loads do not exceed 87% of hydraulic lift capacity or 75% of tipping load.

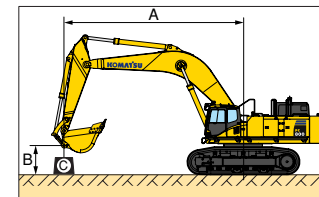

PC800-8R

- Equipment:
- Boom: 8.2 m 26'11"
 - Arm: 4.6 m 15'1"
 - Bucket: 2.8 m³ 3.66 yd³
 - Shoe: 610 mm 24"
 - Counterweight: 9.8 ton 21,610 lb

- A: Reach from swing center
B: Bucket hook height
C: Lifting capacity
Cf: Rating over front
Cs: Rating over side
⊗: Rating at maximum reach

HEAVY LIFTING "OFF"

B \ A	⊗ Maximum		12.0 m 39'		9.0 m 29'		7.5 m 24'		6.0 m 19'		4.5 m 14'		3.0 m 9'	
	Cf	Cs	Cf	Cs	Cf	Cs	Cf	Cs	Cf	Cs	Cf	Cs	Cf	Cs
6.0 m 19'	*6350 *14,000	*6350 *14,000	*7850 *17,300	7700 17,000	*10700 *23,600	*10700 *23,600								
3.0 m 9'	*7300 *16,100	6050 13,300	9300 20,500	7050 15,600	*13,300 *29,400	12400 27,300	*16250 *35,900	*16250 *35,900	*21350 *47,100	*21350 *47,100				
0 m 0'	7950 17,500	5900 13,000	8650 19,000	6450 14,200	14250 31,400	10850 23,900	19150 42,300	14550 32,100	*25900 *57,100	20700 45,600	*14500 *32,000	*14500 *32,000		
-3.0 m -9'	9100 20,100	6750 14,900			13500 29,700	10150 22,300	18150 40,100	13650 30,100	*25950 *57,200	19700 43,400	*23400 *51,600	*23400 *51,600	*15850 *35,000	*15,850 *35,000
-6.0 m -19'	*12600 *27,800	9950 22,000			*13200 *29,100	10400 23,000	*17000 *37,500	13950 30,800	*21750 *48,000	20300 44,700	*28500 *62,900	*28500 *62,900	*28600 *63,000	*28600 *63,000

Unit: kg lb

HEAVY LIFTING "ON"

B \ A	⊗ Maximum		12.0 m 39'		9.0 m 29'		7.5 m 24'		6.0 m 19'		4.5 m 14'		3.0 m 9'	
	Cf	Cs	Cf	Cs	Cf	Cs	Cf	Cs	Cf	Cs	Cf	Cs	Cf	Cs
6.0 m 19'	*7250 *16,000	7100 15,600	*8900 *19,700	7700 17,000	*12300 *27,100	*12300 *27,100								
3.0 m 9'	8050 17,800	6050 13,300	9300 20,500	7050 15,600	*15350 *33,800	12400 27,300	*18600 *41,000	16900 37,300	*24300 *53,500	*24300 *53,500				
0 m 0'	7950 17,500	5900 13,000	8650 19,000	6450 14,200	14250 31,400	10850 23,900	19150 42,300	14550 32,100	27650 61,000	20700 45,600	*16200 *35,800	*16200 *35,800		
-3.0 m -9'	9100 20,100	6750 14,900			13500 29,700	10150 22,300	18150 40,100	13650 30,100	26600 58,600	19700 43,400	*25900 *57,100	*25900 *57,100	*17650 *39,000	*17650 *39,000
-6.0 m -19'	*13200 29,100	9950 22,000			*13750 30,400	10400 23,000	*18500 40,800	13950 30,800	*25050 *55,200	20300 44,700	*32750 *72,200	*32750 *72,200	*31600 *69,700	*31600 *69,700

Unit: kg lb

* Load is limited by hydraulic capacity rather than tipping. Ratings are based on SAE standard No. J1097. Rated loads do not exceed 87% of hydraulic lift capacity or 75% of tipping load.

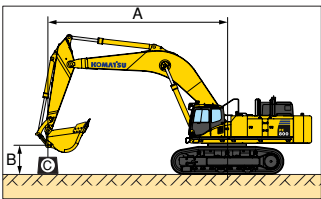

PC800-8R

Equipment:

- Boom: **8.2 m 26'11"**
- Arm: **5.6 m 18'4"**
- Bucket: **2.8 m³ 3.66 yd³**
- Shoe: **610 mm 24"**
- Counterweight: **9.8 ton 21,610 lb**

- A: Reach from swing center
- B: Bucket hook height
- C: Lifting capacity
- Cf: Rating over front
- Cs: Rating over side
- ☉: Rating at maximum reach

HEAVY LIFTING "OFF"

Unit: kg lb

B	A	Maximum		12.0 m 39'		9.0 m 29'		7.5 m 24'		6.0 m 19'		4.5 m 14'		3.0 m 9'	
		Cf	Cs	Cf	Cs	Cf	Cs	Cf	Cs	Cf	Cs	Cf	Cs	Cf	Cs
6.0 m 19'		*3950 *8,700	*3950 *8,700	*6950 *15,400	*6950 *15,400										
3.0 m 9'		*4500 *9,900	*4500 *9,900	*9050 *19,900	7050 15,500	*11750 *25,900	*11750 *25,900	*14200 *31,300	*14200 *31,300	*18350 *40,400	*18350 *40,400				
0 m 0'		*5600 *12,400	4700 10,300	8400 18,600	6200 13,700	14150 31,200	10750 23,700	*17800 *39,200	14350 31,700	*24100 *53,100	20850 46,000	*15050 *33,200	*15050 *33,200		
-3.0 m -9'		7300 16,100	5250 11,600	7950 17,500	5750 12,700	13050 28,800	9700 21,400	17700 39,000	13150 29,000	*25600 *56,400	19050 42,100	*20000 *44,100	*20000 *44,100	*12800 *28,200	*12800 *28,200
-6.0 m -19'		9850 21,700	7250 16,000			13000 28,600	9650 21,200	17600 38,800	13100 28,900	*23050 *50,800	19200 42,300	*31050 *68,400	*31050 *68,400	*22450 *49,500	*22450 *49,500

HEAVY LIFTING "ON"

Unit: kg lb

B	A	Maximum		12.0 m 39'		9.0 m 29'		7.5 m 24'		6.0 m 19'		4.5 m 14'		3.0 m 9'	
		Cf	Cs	Cf	Cs	Cf	Cs	Cf	Cs	Cf	Cs	Cf	Cs	Cf	Cs
6.0 m 19'		*4700 *10,300	*4700 *10,300	*8000 *17,600	7800 17,200										
3.0 m 9'		*5300 *11,600	4850 10,700	9250 20,400	7050 15,500	*13600 *30,000	12600 27,700	*16300 *36,000	*16300 *36,000	*20900 *46,100	*20900 *46,100				
0 m 0'		*6500 *14,300	4700 10,300	8400 18,600	6200 13,700	14150 31,200	10750 23,700	18950 41,800	14350 31,700	*27550 *60,800	20850 46,000	*16800 *37,000	*16800 *37,000		
-3.0 m -9'		7300 16,100	5250 11,600	7950 17,500	5750 12,700	13050 28,800	9700 21,400	17700 39,000	13150 29,000	25950 57,200	19050 42,100	*22200 *49,000	*22200 *49,000	*14350 *31,600	*14350 *31,600
-6.0 m -19'		9850 21,700	7250 16,000			13000 28,600	9650 21,200	17600 38,800	13100 28,900	26050 57,500	19200 42,300	*35400 *78,000	*32550 71,800	*24950 *55,000	*24950 *55,000

* Load is limited by hydraulic capacity rather than tipping. Ratings are based on SAE standard No. J1097. Rated loads do not exceed 87% of hydraulic lift capacity or 75% of tipping load.

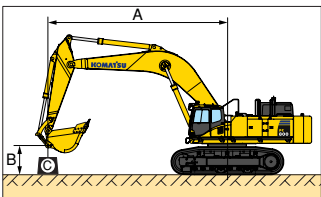

PC800SE-8R

Equipment:

- Boom: **7.1 m 23'4"**
- Arm: **2.9 m 9'8"**
- Bucket: **4.0 m³ 5.23 yd³**
- Shoe: **610 mm 24"**
- Counterweight: **9.8 ton 21,610 lb**

- A: Reach from swing center
- B: Bucket hook height
- C: Lifting capacity
- Cf: Rating over front
- Cs: Rating over side
- ☉: Rating at maximum reach

HEAVY LIFTING "OFF"

Unit: kg lb

B	A	Maximum		9.0 m 29'		7.5 m 24'		6.0 m 19'		4.5 m 14'		3.0 m 9'	
		Cf	Cs	Cf	Cs	Cf	Cs	Cf	Cs	Cf	Cs	Cf	Cs
6.0 m 19'		*12650 *27,900	10350 22,800	*13150 *29,000	12650 27,900	*14700 *32,400	*14700 *32,400						
3.0 m 9'		11300 24,900	8550 18,900	14850 32,800	11450 25,200	*18200 *40,100	15850 34,900	*23800 *52,500	22950 50,600				
0 m 0'		11550 25,400	8650 19,100	13850 30,500	10450 23,000	18800 41,400	14200 31,300	*26650 *58,800	20400 45,000	*28900 *63,800	*28900 *63,800		
-3.0 m -9'		*14900 *32,800	11350 25,000			*18350 *40,500	14050 31,000	*23950 *52,800	20400 45,000	*31500 *69,500	*31500 *69,500	*36900 *81,300	*36900 *81,300

HEAVY LIFTING "ON"

Unit: kg lb

B	A	Maximum		9.0 m 29'		7.5 m 24'		6.0 m 19'		4.5 m 14'		3.0 m 9'	
		Cf	Cs	Cf	Cs	Cf	Cs	Cf	Cs	Cf	Cs	Cf	Cs
6.0 m 19'		13350 29,400	10350 22,800	*15100 *33,300	12650 27,900	*16800 *37,000	*16800 *37,000						
3.0 m 9'		11300 24,900	8550 18,900	14850 32,800	11450 25,200	20,550 45,300	15850 34,900	*27100 *59,700	22950 50,600				
0 m 0'		11550 25,400	8650 19,100	13850 30,500	10450 23,000	18800 41,400	14200 31,300	27400 60,500	20400 45,000	*32000 *70,500	*32000 *70,500		
-3.0 m -9'		15000 33,100	11350 25,000			18650 41,100	14050 31,000	27400 60,400	20400 45,000	*36050 *79,500	34500 76,000	*40700 *89,700	*40700 *89,700

* Load is limited by hydraulic capacity rather than tipping. Ratings are based on SAE standard No. J1097. Rated loads do not exceed 87% of hydraulic lift capacity or 75% of tipping load.

Transportation specifications (length x height x width)

Backhoe

Specs shown include the following equipment:

- PC800-8R: Boom **8200 mm 26'11"**, Arm **3600 mm 11'10"**, Bucket **3.1 m³ 4.05 yd³**, Shoes **610 mm 24"** double grouser
- PC800SE-8R: Boom **7100 mm 23'4"**, Arm **2945 mm 9'8"**, Bucket **4.0 m³ 5.23 yd³**, Shoes **610 mm 24"** double grouser

3 Kits Transportation

Work equipment assembly (Backhoe)
Weight : PC800-8R : 17.1 t 18.8 U.S.ton
PC800SE-8R: 18.1 t 20.0 U.S.ton

Boom
PC800-8R : 7.9 t : 8530 x 2800 x 1500
8.7 U.S.ton : 28'0" x 9'2" x 4'11"
PC800SE-8R: 7.3 t : 7430 x 2695 x 1500
8.0 U.S.ton : 24'5" x 8'10" x 4'11"

Arm
PC800-8R : 4.0 t : 5120 x 1345 x 750
4.4 U.S.ton : 16'10" x 4'5" x 2'6"
PC800SE-8R: 4.9 t : 4080 x 1695 x 755
5.4 U.S.ton : 13'5" x 5'7" x 2'6"

Bucket
PC800-8R : 2.9 t : 2365 x 1850 x 1845
3.2 U.S.ton : 7'9" x 6'1" x 6'1"
PC800SE-8R: 3.4 t : 2200 x 1950 x 2105
3.7 U.S.ton : 7'3" x 6'5" x 6'11"

Boom & Arm cylinder
PC800-8R : Total 2.3 t 2.6 U.S.ton
PC800SE-8R : Total 2.5 t 2.8 U.S.ton

4 Kits Transportation

Work equipment assembly (Backhoe)
Weight : PC800-8R : 17.1 t 18.8 U.S.ton
PC800SE-8R: 18.1 t 20.0 U.S.ton

Boom
PC800-8R : 7.9 t : 8530 x 2800 x 1500
8.7 U.S.ton : 28'0" x 9'2" x 4'11"
PC800SE-8R: 7.3 t : 7430 x 2695 x 1500
8.0 U.S.ton : 24'5" x 8'10" x 4'11"

Arm
PC800-8R : 4.0 t : 5120 x 1345 x 750
4.4 U.S.ton : 16'10" x 4'5" x 2'6"
PC800SE-8R: 4.9 t : 4080 x 1695 x 755
5.4 U.S.ton : 13'5" x 5'7" x 2'6"

Bucket
PC800-8R : 2.9 t : 2365 x 1850 x 1845
3.2 U.S.ton : 7'9" x 6'1" x 6'1"
PC800SE-8R: 3.4 t : 2200 x 1950 x 2105
3.7 U.S.ton : 7'3" x 6'5" x 6'11"

Boom & Arm cylinder
PC800-8R : Total 2.3 t 2.6 U.S.ton
PC800SE-8R : Total 2.5 t 2.8 U.S.ton

Loading Shovel

Specs shown include the following equipment:

- PC800-8R : Boom **4600 mm 15'1"**, Arm **3400 mm 11'2"**, Bucket **4.5 m³ 5.9 yd³**, Shoes **610 mm 24"** double grouser

3 Kits Transportation

Work equipment assembly (Loading shovel)
Width : 2320 7'7"
Weight : 19.6 t 21.6 U.S.ton

Work equipment assembly (Loading shovel)
Width : 2320 7'7"
Weight : 19.6 t 21.6 U.S.ton

Base machine
(Both PC800-8R and PC800SE-8R are designed with the same weight and dimensions.)
Width : 3515 11'6"
Weight : 47.4 t 52.2 U.S.ton

Upper structure
Width : 3290 10'10"
Weight : 26.3 t 29.0 U.S.ton

Undercarriage
Weight : 21.2 t [10.6 t x 2]
23.4 U.S.ton [11.7 U.S.ton x 2]

Base machine
(Both PC800-8R and PC800SE-8R are designed with the same weight and dimensions.)
Width : 3515 11'6"
Weight : 47.6 t 52.5 U.S.ton

Others
Weight : 10.1 t 11.1 U.S.ton

Weight : 9.8 t 10.8 U.S.ton

Others
Weight : 10.1 t 11.1 U.S.ton

Weight : 9.8 t 10.8 U.S.ton

Others
Weight : 10.1 t 11.1 U.S.ton

Weight : 9.8 t 10.8 U.S.ton